



Children's services – occupational health and safety compliance kit:

How to control the risks
from the most common
hazardous tasks in the
children's services sector

About this kit

This kit has been developed in response to requests for practical advice about:

1. the main hazardous tasks that cause workplace injuries in centre-based services for children aged under six years old (eg childcare centres and kindergartens).
2. how to control the risks associated with these tasks to prevent injuries and comply with the *Occupational Health and Safety Act 2004* (OHS Act).

This kit describes the **six most common hazardous tasks** that cause workplace injuries in the children's services sector.*

It includes six **Health and Safety Solutions** that outline ways to control the risks associated with these tasks, and a range of other information about occupational health and safety (OHS).

It is acknowledged that some of the hazardous tasks described in this kit relate to engaging with children (eg working at low levels, lifting children onto equipment or moving play equipment).

Organisations are encouraged to discuss **how** these tasks are undertaken so both the workers' and children's needs are addressed. This may include considering the equipment, the environment or the systems in the workplace. Workers' and children's health and safety are interlinked and reducing the risks to workers can improve the service for children.

The solutions in this kit are not the only ways to control the risks associated with these hazardous tasks. Depending on the circumstances, a workplace may need to implement multiple or different solutions to those in this kit.

*Based on WorkSafe Victoria's injury statistics from 2004 to 2008. These hazardous tasks may not be present in all children's services working environments

Workplace injuries in the children's services sector

Between 2004 and 2008, nearly 900 workers were seriously injured while working in childcare centres and kindergartens in Victoria. Seventy per cent of these injuries were sprains, strains, fractures and soft tissue injuries, also known as musculoskeletal injuries.**

These injuries are preventable.

**Based on WorkSafe Victoria's injury statistics from 2004 to 2008.

The six most common hazardous tasks in the children's services sector:

- 1. Lifting children in/out of cots and highchairs or on/off change tables** – Bending, twisting and reaching to lift children due to the design, placement or characteristics of cots, highchairs or change tables.
- 2. Working at low levels** – Awkward postures, tripping or falling due to sitting on children's furniture or the floor.
- 3. Moving equipment** – Lifting, moving, carrying, pushing or pulling heavy or awkward indoor and outdoor play equipment.
- 4. Storing supplies and equipment** – Tripping, falling or being hit by falling objects due to overcrowded or poorly designed storage areas. Bending, lifting, twisting and using high or unexpected force to move heavy or awkward objects.
- 5. Using office areas** – Awkward body postures due to poorly designed, cluttered or inappropriate office areas. Tripping, falling or being hit by falling objects due to poorly designed office areas.
- 6. Maintaining indoor and outdoor areas** – Falling from height while standing on chairs and tables to display artwork. Tripping or falling over toys or on poorly maintained, uneven or wet floor surfaces.

Preventing these injuries

Read the information inside this kit.

Consult with workers, health and safety representatives (HSRs) and managers about OHS and on ways to control the risks associated with these hazardous tasks. You can download more copies of this kit at [worksafe.vic.gov.au/children](https://www.worksafe.vic.gov.au/children).

Refer to:

- the 'further information' section on the back of this kit and in each Health and Safety Solution to learn more about how to control the risks.
- the diagram opposite to select solutions for the workplace that provide the highest level of protection and reliability possible.

Implement solutions to eliminate or reduce the risks associated with these hazardous tasks so far as is practicable, to prevent injuries from occurring.

Regularly review any solutions that are put in place to check they are still working.

Continue to identify hazardous tasks and put solutions in place in consultation with workers and HSRs.

Encourage reporting of injuries or near misses so they can be analysed and solutions put in place to prevent further incidents.

Engage someone suitably qualified in health and safety if help is needed to make improvements.

Expand this kit by adding extra resources.

Important note

The information in this kit is general guidance only and focuses on the six most common hazardous tasks in the children's services sector. It should not be viewed as a definitive guide to the law, and should be read in conjunction with the *Occupational Health and Safety Act 2004*. This kit does not cover all your requirements under health and safety laws.

Compliance with OHS laws is a continuous process that involves the development and maintenance of a healthy and safe work environment, and safe systems of work. This ongoing process must be sufficient to fulfil the duty holder's obligations under OHS laws.

WorkSafe inspectors check the risks associated with these hazardous tasks are eliminated or reduced so far as is reasonably practicable.

Highest

- Eliminate the hazards or eliminate the risk

Most



Level of protection



Lowest

- Reduce the risk by:
 - altering the workplace layout or environment
 - changing work practices eg how work is done, by whom, where, when and how often
 - changing objects used in the task eg reducing, replacing or modifying object weight, dimensions or characteristics
 - using mechanical aids or
 - using any combination of the above.



Reliability



Least

- Provide information, training and instruction to control the risks only if none of the above is reasonably practicable.

Responsibilities*

Employers

Employers can include non-profit organisations, private companies, community organisations, franchises, local governments or other businesses that have management control of the workplace.

Employers have a responsibility under the OHS Act to provide a healthy and safe working environment, so far as is reasonably practicable. This duty extends to any person who may be affected by the organisation's activities (eg other people present at the workplace such as children or volunteers).

Part of this responsibility includes identifying and controlling the risks from the common hazardous tasks in this kit.

Employers cannot remove or pass on their health and safety responsibilities by way of a contractual arrangement with anyone.

Under the OHS Act employers must:

- provide and maintain a workplace, equipment and systems of work that are safe and do not pose health risks
- provide adequate amenities
- provide information, instruction, training or supervision for employees to work safely and without risks to health
- implement arrangements for the safe use, handling, storage and transport of chemicals and hazardous substances
- monitor the health of employees and the conditions of the workplace, and keep records on the health and safety of employees
- employ or engage a suitably qualified person to provide advice on the health and safety of employees
- consult with employees and HSRs on matters that may affect their health, safety or welfare
- provide employees with information in appropriate languages about health and safety arrangements in the workplace, and who employees can contact to ask questions or to make a complaint
- notify WorkSafe immediately upon becoming aware of an incident that results in death or serious injury.

Some workers in children's services are employed by labour hire agencies to work in another organisation. These workers are sometimes called contractors, agency staff or temporary staff. In these situations, both the labour hire agency and the host employer have responsibilities to protect the health and safety of workers.

Where there are multiple employers who manage or control the workplace (eg in a franchiser/franchisee arrangement or a co-located service with shared work areas), all employers have responsibilities to provide a healthy and safe workplace.

Employees

Employees have a responsibility under the OHS Act to take reasonable care for their own health and safety and for the health and safety of others who may be affected by their actions while at work.

*Visit [worksafe.vic.gov.au](https://www.worksafe.vic.gov.au) for more information about these and other responsibilities.



Before you implement any solutions

Employers must consult with workers and health and safety representatives (if you have them) about OHS matters that directly affect them or are likely to directly affect them.

Select solutions that are most reliable and provide the highest level of protection possible using the diagram above to help you.

To determine what is reasonably practicable visit [worksafe.vic.gov.au](https://www.worksafe.vic.gov.au) and search 'reasonably practicable'.

Lifting children in/out of cots and highchairs or on/off change tables

August 2011

What is the problem?

Workers experience musculoskeletal injuries (eg sprains, strains, fractures and soft tissue injuries) from the design, placement and characteristics of equipment children are lifted onto/into (eg cots, highchairs and change tables).

The implementation of risk controls must not introduce any new hazards or risks to workers or children.

What are the risks?

Workers are at risk of injuries from bending, twisting and reaching due to:

- poorly designed work areas
- insufficient space
- equipment that is poorly positioned
- equipment with a low working height (eg cots with bases below mid thigh height)
- equipment that is not adjustable (eg cots with fixed sides)
- equipment that does not have removable parts (eg fixed highchair trays)
- mismatch between equipment adjustability for children and desired adjustability for workers
- effort involved in lifting and lowering children
- unexpected or unplanned movement by children

What are solutions to the problems?

Organisations are encouraged to discuss how and when children are lifted onto equipment so workers' and children's needs are addressed.

Cots

- Reduce the distance the worker needs to bend and reach to lift the child by using cots:
 - that are designed for day nurseries with a higher working height
 - in the higher base position if the cot is designed with two base positions. Ensure this meets the children's safety requirements (eg child cannot climb out)
 - with drop-down sides.
- Prepare cots before children are lifted so sides are dropped down.
- Provide sufficient access around cots so workers can lift or lower children without reaching over the length of the cot.

- Maintain wheels, wheel-locks and drop-down sides on cots so they work effectively.
- If cots are wheeled:
 - provide appropriately sized wheels
 - assess floor surfaces for minimal friction for cots to be wheeled with minimal resistance. Modify existing floor surfaces if necessary.

Highchairs

- Use highchairs that have removable or adjustable trays so the tray can be put in place after children are seated.
- Use height adjustable highchairs for children to safely seat themselves.
- Maintain wheels and wheel-locks on highchairs.
- If highchairs are wheeled:
 - they should have appropriately sized wheels with lockable castors
 - assess floor surfaces for minimal friction so they can be wheeled with minimal resistance. Modify existing floor surfaces if necessary.

Change tables

- Use change tables that provide a space for workers feet underneath the table so they can stand close to the child being changed.
- Use change tables that are height adjustable to waist height for the worker.
- Use change tables with steps that have:
 - a handrail so children who can walk access the change table themselves
 - removable, retractable and lockable steps so workers do not have to reach over the steps when changing children
 - easy access so the worker does not have to repeatedly bend to access or put away the steps.
- Ensure steps are well maintained and easy for the worker to move.
- Provide sufficient access around the change table so workers can change the child from a front position (child's feet facing worker's stomach).
- Position changing supplies within easy reach to reduce the need for the worker to repeatedly twist, bend or use an extended reach.

A Health and Safety Solution **Lifting children in/out of cots and highchairs or on/off change tables**

Systems

- Assess if, how and when each child is lifted onto, into or from equipment.
- Provide reporting processes so safety issues can be identified and fixed as soon as possible.
- Provide workers with training, information, instruction and supervision on documented work procedures and use of equipment.
- Schedule and record regular inspections, and maintenance of all areas of the workplace and equipment.
- Use a system to rotate tasks among workers to reduce their overall exposure to the risks associated with these tasks.

The problem



Cot base is non-adjustable and close to the ground, requiring workers to reach and bend to lift children into/from the cot.

The problem



A change table without steps requires workers to bend, reach and twist to lift children onto/from the change table.

The change table is designed so the child is side on to the worker when being changed, requiring reaching and twisting.

A solution



Cot is designed with a higher working height, reducing the workers need to reach and bend to lift children into/from the cot.

Cot has appropriately sized wheels and wheel-locks and worker can stand with their feet under the cot to reduce reaching distances.

A solution

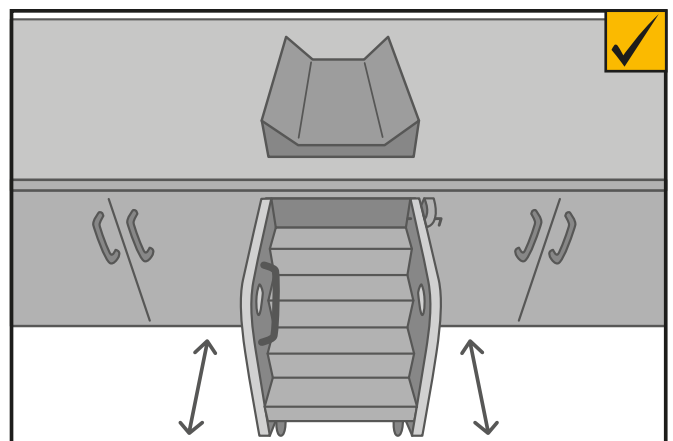

A change table with stairs and handrails enables children to be assisted onto the change table without being lifted.

Retractable, lockable, and easily accessible steps reduce the need for the worker to bend.

The change table is designed so the child's feet are facing the worker, reducing the need for the worker to twist. There is space under the change table so the worker can easily reach the child.

Further Information

WorkSafe Advisory Service

Toll-free 1800 136 089

Email info@worksafe.vic.gov.au

worksafe.vic.gov.au

Related WorkSafe Health and Safety Solutions

- *Working at low levels in children's services*
- *Moving equipment in children's services*
- *Storing supplies and equipment in children's services*
- *Using office areas*
- *Maintaining indoor and outdoor areas in children's services*

Related WorkSafe publications

- *Childcare – Designing change table steps for children, 2009*
- *Injury Hotspots – Children's services, 2008*

Other related publications

- *Children's Services Regulations, 2009*
(available from legislation.vic.gov.au)
- *Emergency Management Guidelines, 2010*
(available from education.vic.gov.au)

Australian Standards

- *AS/NZS 2130:1998, Cots for day nursery, hospital and institutional use – Safety requirements*

NOTE: The information in this publication is protected by copyright. WorkSafe Victoria encourages the free transfer, copying and printing of the information in this guidance material if such activities support the purpose for which this guidance is intended.

Working at low levels in children's services

What is the problem?

Workers experience musculoskeletal injuries (eg sprains, strains, fractures and soft tissue injuries) from working at low levels in children's services. Working at low levels includes working at floor level, crouching, kneeling or sitting on children's furniture. It is acknowledged that working at low levels may be necessary for engaging with children. Organisations are encouraged to discuss how tasks at low levels are undertaken so the worker's and children's needs are addressed safely.

What are the risks?

Workers may be at risk of injuries from:

- awkward postures due to sitting on children's furniture or the floor
- awkward postures due to crouching or kneeling at floor level
- tripping or falling due to raising or lowering the body to/from low levels
- no adult-sized seating options being available
- working at low levels for long durations.

What are solutions to the problems?

Equipment

- Provide adult sized chairs that are adjustable for seat height, backrest height and tilt. For example:
 - use adult-sized chairs that can be raised and lowered beyond the usual lowering range to ensure workers can sit in a supported posture while engaging with children at eye level
 - check whether castors or glides should be chosen. This depends on the task the chair is required for and whether the chair is permanently located in an area or wheeled in and out as required. As a general principle:
 - chairs with glides should not be considered mobile or carried in and out of areas for use
 - chairs with castors can be moved easily with brake options to prevent movement

- any administrative procedure implemented to control risks (eg the implementation of brakes if required) will rely on appropriate instruction, training and supervision.
- Provide children's chairs that are higher and matched to the age/size of children.
- Provide additional seating options for workers (eg adult-sized chairs, reading chairs or couches).
- Include features in outdoor play areas for workers to sit on as an alternative to squatting, crouching or sitting at ground level.

Systems

- Reduce tasks completed at low levels.
- For tasks completed at low levels:
 - provide a surface to cushion the point of contact between the worker's body and the floor
 - limit the duration the task is conducted for
 - rotate the task to limit worker's exposure to risks.
- Provide workers with information, instruction and supervision on documented work procedures and use of equipment and aids.
- Provide reporting processes so safety issues can be identified and fixed as soon as possible.
- Schedule and record regular inspections and maintenance of all areas of the workplace and equipment.

A Health and Safety Solution

The problem



Workers sitting on children's furniture and the floor to work at low levels.

A solution



Adult sized chair that can be adjusted, raised and lowered to enable the worker to sit in a supported posture while working at low levels.

Further Information

WorkSafe Advisory Service

Toll-free 1800 136 089

Email info@worksafe.vic.gov.au

worksafe.vic.gov.au

Related WorkSafe Health and Safety Solutions

- *Lifting children in/out of cots and highchairs or on/off change tables*
- *Moving equipment in children's services*
- *Storing supplies and equipment in children's services*
- *Using office areas in children's services*
- *Maintaining indoor and outdoor areas in children's services*

Related WorkSafe publications

- *Manual Handling Code of Practice, 2000*
- *Officewise, 2006*

Related publications

- *AS/NZS 4438:1997, Height adjustable swivel chairs*
- *Children's Services Regulations, 2009 (available from legislation.vic.gov.au)*
- *Design guide for Victorian children's services, 2009 (available from education.vic.gov.au)*

Moving equipment in children's services

What is the problem?

Workers in the children's services sector experience musculoskeletal injuries (eg sprains, strains, fractures and soft tissue injuries) from manually moving or carrying equipment.

Equipment includes large, bulky, awkward or heavy objects such as indoor and outdoor play equipment (eg climbing frames, model kitchens, bookcases or block trolleys). Equipment also includes objects such as evacuation cots and children's furniture.

Equipment is frequently moved in children's services to provide children with a stimulating or changing environment. Organisations are encouraged to discuss how equipment is moved so the needs of workers and children are addressed safely.

What are the risks?

Workers may be at risk of injuries from:

- bending, twisting and exerting high or unexpected force due to manually lifting, moving or carrying heavy or awkward indoor and outdoor equipment
- no aids being available to move equipment (eg trolleys)
- poorly maintained or inappropriate ladders
- an insufficient number of people to undertake the task
- pushing or pulling evacuation cots that are difficult to manoeuvre over uneven surfaces or in small spaces.

What are solutions to the problems?

Equipment

- Replace heavy or awkward equipment with lighter equipment.
- Replace heavy or awkward equipment with equipment with lockable wheels so it can be easily moved.
- Store equipment close to where it is used.
- Use trolleys for moving heavy or awkward objects rather than manually lifting and carrying objects. For example:
 - match the trolley to the weight and dimensions of the objects that are being moved
 - designate appropriate routes for trolleys so they are not pushed over surfaces with a high level of friction or resistance or lifted over structures such as steps.
- Use sandpit covers that are segmented or rolled to reduce manually lifting the entire cover.
- Store objects in smaller rather than larger containers to avoid having to lift and balance heavy loads.
- Use lightweight, sturdy, stackable containers with wheels and handles to store or move objects.

Evacuation cots

- Measure doorways to ensure they are wide enough for evacuation cots.
- Fit evacuation cots with large diameter wheels (eg 100-150mm) to assist with the negotiation of external surface obstacles. Wheels should be sturdy, lockable and well maintained to move the cot with minimal resistance.
- Assess the floor and ground surfaces of the evacuation route for minimal friction (eg no thick carpet, tanbark or broken concrete), and modify existing surfaces where necessary.
- Remove or modify any structures the evacuation cot needs to be lifted over (eg steps or raised door frames).
- Ensure emergency exits are accessible at all times and are not locked or blocked.

A Health and Safety Solution

Systems

- Consider the weight, size and manoeuvrability when purchasing or replacing equipment.
- Identify and label the weight, size and handling instructions for equipment that is moved (eg whether equipment must be moved with an appropriate aid such as wheels or a trolley or if it can only be moved with two people).
- If facilities are shared with other organisations, designate how equipment should be moved, who will move equipment and when it will be moved.
- Provide workers with information, instruction and supervision on documented work procedures and use of equipment and aids.
- Provide reporting processes so safety issues can be identified and fixed as soon as possible.
- Schedule and record regular inspections and maintenance of all areas of the workplace and equipment.

The problem



Worker is at risk of injury when manually lifting and carrying heavy or awkward objects.

A solution



Trolley used to move playground equipment and toys, reducing the need to manually lift and carry objects. Large wheels help move the trolley over uneven surfaces.

Further Information

WorkSafe Advisory Service

Toll-free 1800 136 089

Email info@worksafe.vic.gov.au

worksafe.vic.gov.au

Related WorkSafe Health and Safety Solutions

- *Lifting children in/out of cots and highchairs or on/off change tables*
- *Working at low levels in children's services*
- *Storing supplies and equipment in children's services*
- *Using office areas in children's services*
- *Maintaining indoor and outdoor areas in children's services*

Related WorkSafe publication

- *Manual Handling Code of Practice, 2000*

Other related publications

- *Children's Services Regulations, 2009 (available from education.vic.gov.au)*
- *Design guide for Victorian children's services, 2009 (available from education.vic.gov.au)*
- *Outdoor play guide for Victorian children's services, 2007 (available from education.vic.gov.au)*

Australian Standards

- *AS/NZS 4422:1996, Playground surfacing – specifications, requirements and test method*
- *AS/NZS 4685.1-200,4 Playground equipment safety*

Storing supplies and equipment in children's services

What is the problem?

Workers in the children's services sector experience musculoskeletal injuries (eg sprains, strains, fractures and soft tissue injuries) from moving supplies and equipment in storage areas.

What are the risks?

Workers may be at risk of injuries from:

- tripping or falling due to overcrowded or poorly designed storage areas
- being hit by falling objects due to unstable or insufficient shelving
- bending, twisting and exerting high or unexpected force due to manually lifting, moving or carrying objects
- bending and reaching due to placement of objects above shoulder height or below knee height
- no ladders or step platforms available to access higher shelves
- poorly maintained or inappropriate ladders.
- no aids available to move supplies or equipment (eg trolleys).

What are solutions to the problems?

Equipment

- Fix shelving to the floor and walls of the storage area.
- Use shelving with a safe working load limit (designated by the manufacturer) and do not exceed this weight limit.
- Maintain shelving and replace any shelving that is cracked, loose or damaged.
- Store objects in smaller containers to avoid having to lift and balance heavy loads.
- Use lightweight, sturdy, stackable containers with wheels and handles to store or move objects.
- Maintain storage area doors so they can be easily opened and closed by workers.
- Design and provide specific storage areas for outdoor or larger equipment.
- If an outdoor storage shed is used, fix the shed securely to the ground.

Task

- Place items frequently used in easy-to-access shelves between shoulder and knee height.
- Store heavier objects between knee and shoulder height rather than at floor level or overhead.
- Match items stored to available shelving size, space and depth. Avoid overcrowding objects or stacking objects on top of each other.
- Separate flammables, paints and chemicals from other stored objects.
- Separate storage of maintenance equipment (eg lawnmowers) from play equipment.
- Use ladders or step platforms to access higher shelves. For example:
 - select the most appropriate ladder for the task (industrial/domestic rating, height, base width)
 - step platforms provide a larger, more stable work surface than ladders
 - place ladders or step platforms squarely on firm, non-slip surfaces
 - maintain three points of contact (eg two feet and at least one hand or two hands and at least one foot) when ascending, descending or standing on ladders
 - inspect ladders or step platforms regularly. Repair or replace ladders where rungs, steps, treads or top plates are missing, worn, damaged or loose
 - stand no higher than the second tread below the top plate of ladders
 - store step platforms or ladders where workers can easily access them when required. Milk crates, chairs, boxes or play equipment should not be used to reach higher objects.

If mezzanine floors are used for storage

- Store items within the safe working load limit of the mezzanine floor.
- Access the mezzanine floor by stairs with handrails, not a ladder.
- Provide handrails and toe boards around the perimeter of mezzanine floors to prevent people or objects from falling.

A Health and Safety Solution

Systems

- Regularly review supplies and equipment in storage areas, and discard objects that do not need to be retained or have not been used within a designated timeframe (eg 12 months).
- Provide a layout plan of where specific items should be placed in storage areas.
- Identify and label the weight, size and handling instructions for stored objects (eg whether object must be stored in a specific place and whether it should be moved with an appropriate aid such as a trolley).
- Provide workers with information, instruction and supervision on documented work procedures and use of equipment and aids.
- Provide reporting processes so safety issues can be identified and fixed as soon as possible.
- Schedule and record regular inspections and maintenance of all areas of the workplace and all equipment.

The problem

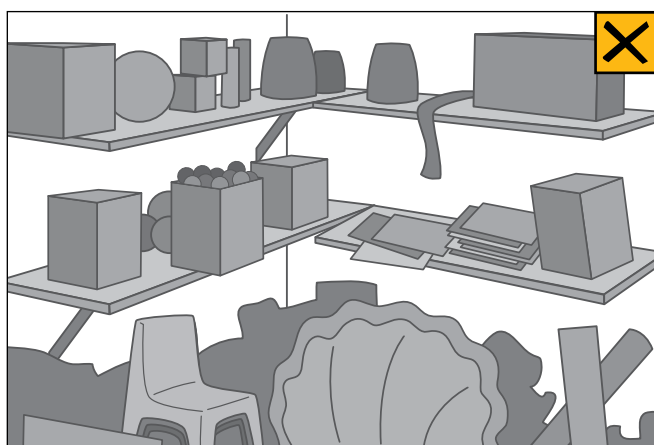

Overcrowded storage area with poorly maintained shelves. Heavy objects are placed above shoulder height. Inadequate access for trolleys or step platforms/ladders

A solution

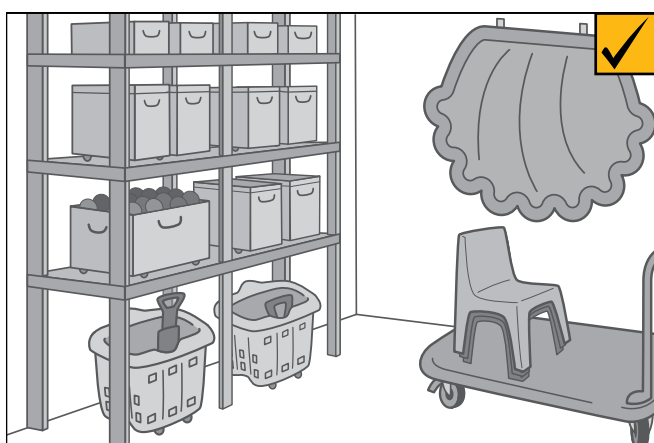

Shelving that is maintained, secured to the wall and has a safe working load that is not exceeded. Objects are stored in lightweight, sturdy, stackable containers with wheels and handles. Adequate space for trolleys or step platforms/ladders

Further Information

WorkSafe Advisory Service

Toll-free 1800 136 089
Email info@worksafe.vic.gov.au
worksafe.vic.gov.au

Related WorkSafe Health and Safety Solutions

- *Lifting children in/out of cots and highchairs or on/off change tables*
- *Working at low levels in children's services*
- *Moving equipment in children's services*
- *Using office areas in children's services*
- *Maintaining indoor and outdoor areas in children's services*

WorkSafe publications

- *Manual Handling Code of Practice, 2000*
- *Prevention of falls – ladders, 2005*
- *Prevention of falls – mezzanines, 2005*

Other publications

- *AS 1657-1992, Fixed platforms, walkways, stairways and ladders – Design, construction and installation*
- *AS/NZS 1892.5:2000, Portable ladders – Selection, safe use and care*
- *Children's Services Regulations, 2009 (available from education.vic.gov.au)*
- *Design guide for Victorian children's services, 2009 (available from education.vic.gov.au)*
- *Outdoor play guide for Victorian children's services, 2007 (available from education.vic.gov.au)*

Using office areas

May 2011

What is the problem?

Using office areas that are unsuitable (eg poorly designed or cluttered) for computer or administrative tasks.

What are the risks?

Workers may be at risk of musculoskeletal injuries (eg sprains, strains, fractures and soft tissue injuries) to the back, neck or shoulders when using awkward postures, or exerting high or unexpected force in office areas.

Common sources of risk include:

- poorly designed or cluttered office areas
- prolonged and intense keyboard and mouse use and high demands on vision
- placement of objects above shoulder height or below knee height
- manually lifting or moving heavy objects
- inappropriate seating
- supporting the telephone on the shoulder when using a computer or writing
- sustained mental effort and peak demands or set work rates
- insufficient time to complete work.

Workers may also be at risk of injuries from slips and trips or from being struck by objects due to:

- cluttered or poorly maintained office areas
- poorly maintained floor surfaces
- unsecured filing cabinets or unstable shelving.

What are solutions to the problems?

Systems

Develop systems of work that:

- match the numbers of workers to the task and environment
- alternate repetitive tasks with tasks requiring different postures and movements
- regularly review supplies and equipment and discard objects that don't need to be retained or have not been used within a designated timeframe (eg 12 months)
- provide workers with information, instruction, training and supervision in relation to work procedures and use of equipment

- identify and report safety issues so they can be fixed as soon as possible
- schedule and record regular inspections and maintenance of all areas of the workplace and equipment
- allocate sufficient time to complete work tasks.

Computers, desks and chairs

- Provide a height-adjustable desk so workers can sit comfortably at the desk with their feet flat on the floor. If the desk is not height adjustable, provide a footstool.
- Provide chairs that can be easily adjusted and have a five-star base.
- Provide information to workers on chair adjustments/ergonomics. For example:
 - adjust the height of the chair so the forearms are parallel to the desk when elbows are at 90 degrees or more
 - adjust the backrest of the chair so it supports the lower back
 - remove armrests if they restrict the ability to move closer to the desk or cause the shoulders to be raised when typing.
- Position the top of the computer screen at eye level, at arms length and away from sources of glare such as windows or lights.
- If laptops are used for long periods, reduce awkward postures by using a laptop stand, separate computer monitor and/or a separate keyboard and mouse.
- Provide adequate space for workstations.
- Keep the space under the desk free from objects or clutter.
- Secure cables under computer desks to minimise tripping hazards.
- Position computer keyboard and mouse to avoid overstretching.
- Use document holders to avoid working from documents that are flat on the desk.
- Place frequently used items within easy reach.
- Use a telephone headset to avoid awkward postures.
- Take regular breaks away from the desk to stand, relax eyes, and stretch or perform other tasks.

(Continued over page)

A Health and Safety Solution Using office areas

Filing cabinets and shelving

- Secure filing cabinets to the wall or use filing cabinets with anti-tilt features.
- Fix shelving to the floor and walls of the office area.
- Use shelving with a safe working load limit (designated by the manufacturer) and do not exceed this weight limit.
- Maintain shelving and replace any shelving that is cracked, loose or damaged.
- Place items frequently used in easy-to-access shelves, between shoulder and knee height.

- Store heavier objects between knee and shoulder height rather than at floor level or overhead.
- Store objects in smaller containers to avoid having to lift and balance heavy loads.

Environment

- Maintain floor areas to remove uneven or damaged surfaces that may cause people to trip.
- Install additional power points to avoid stretching electrical cords across floors.

The problem



The office is cluttered and has inadequate space under the desk for the worker's legs.

A solution



The desk, chair and computer equipment are adjustable for the worker. Storage systems are used to reduce clutter. A window blind reduces glare.

Further information

WorkSafe Advisory Service

Toll-free 1800 136 089

info@worksafe.vic.gov.au

worksafe.vic.gov.au

Related WorkSafe publications

Officewise, 2006

Manual Handling Code of Practice, 2000

Working safely in community services, 2006

Injury hotspot – Community support services, 2008

WorkSafe OHS compliance kits –

Children's services, disability service, home care, community support services

Volunteer health and safety –

A handbook for community service organisations, 2008

The information presented in this Health and Safety Solution is intended for general use only. Whilst every effort has been made to ensure the accuracy and completeness of the Health and Safety Solution, the advice contained herein may not apply in every circumstance. Accordingly, the Victorian WorkCover Authority cannot be held responsible, and extends no warranties as to the suitability of the information for your specific circumstances; or actions taken by third parties as a result of information contained in the Health and Safety Solution.

Maintaining indoor and outdoor areas in children's services

What is the problem?

Workers in the children's services sector experience musculoskeletal injuries (eg sprains, strains, fractures and soft tissue injuries) when maintaining indoor and outdoor areas.

What are the risks?

Workers may be at risk of injuries from:

- falling from height when displaying artwork in indoor areas without appropriate aids (eg ladders)
- tripping and falling due to toys that haven't been packed away
- tripping or falling due to poorly maintained or uneven floor surfaces
- tripping or falling due to wet floor surfaces
- awkward postures due to working at floor level to tidy up
- repetitive movements required to clean surfaces.

What are solutions to the problems?

Equipment

- Use a pulley system so stringlines for displaying artwork can be raised and lowered from ground level.
- Use ladders or step platforms to reach higher objects. For example:
 - select the most appropriate ladder for the task (eg industrial/domestic rating, height, base width)
 - step platforms provide a larger, more stable work surface than ladders
 - place ladders or step platforms squarely on firm, non-slip surfaces
 - maintain three points of contact (eg two feet and at least one hand or two hands, and at least one foot) when ascending, descending or standing on a ladder
 - inspect step ladders or step platforms regularly. Repair or replace ladders where rungs, steps, treads or top plates are missing, worn, damaged or loose
 - tables, chairs, play equipment or milk crates should not be used to reach higher objects

- stand no higher than the second tread below the top plate of step ladders
- store step platforms or ladders where workers can easily access them when required.
- Provide storage containers that are appropriately sized and shaped, sturdy, lightweight and have wheels/handles so toys can be packed away easily.

Environment

- Maintain floor and ground surfaces. Replace uneven or damaged surfaces that cause people to trip (eg damaged carpets, mats, tiles, linoleum, concrete or impact-absorbing surfaces).
- Regularly maintain outdoor areas to contain materials such as tanbark or sand within designated areas.
- Install additional power points to avoid stretching electrical cords across floors.
- Use a surface colour or texture change to highlight where surfaces suddenly change from hard to soft or where a change in level is difficult to see.
- Immediately clean up spills, regardless of how small the spill is or whether it occurs in a staff-only or child-accessible area.

Systems

- Encourage children to assist in picking up toys.
- Tidy areas frequently so toys do not accumulate on the floor.
- Schedule and record regular inspections and maintenance of all areas of the workplace and all equipment.
- Regularly review equipment. Discard equipment and objects that do not need to be retained or have not been used within a designated timeframe (eg 12 months).
- Provide workers with information, instruction and supervision on documented work procedures and use of equipment and aids.
- Provide reporting processes so safety issues can be identified and fixed as soon as possible.

A Health and Safety Solution

The problem



Worker is at risk of falling from height when an appropriate aid is not used to reach higher objects.

A solution

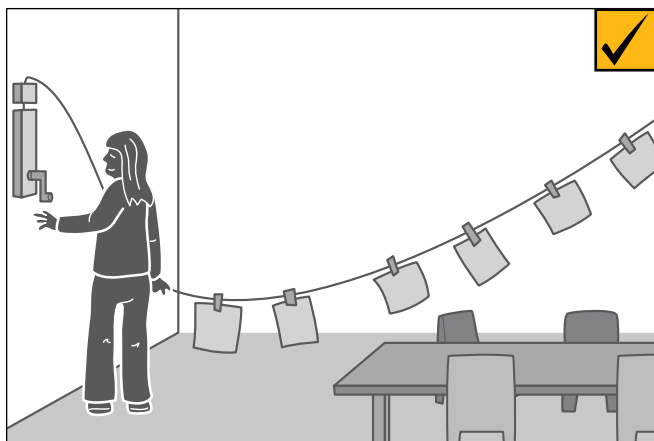

A pulley system and stringline can be raised and lowered to display artwork.

Further Information

WorkSafe Advisory Service

Toll-free 1800 136 089
Email info@worksafe.vic.gov.au
worksafe.vic.gov.au

Related WorkSafe Health and Safety Solutions

- *Lifting children in/out of cots and highchairs or on/off change tables*
- *Working at low levels in children's services*
- *Moving equipment in children's services*
- *Storing supplies and equipment in children's services*
- *Using office areas in children's services*

Related WorkSafe publications

- *Manual Handling Code of Practice, 2000*
- *Injury hotspots – Children's Services, 2008*
- *Injury hotspots – Slips trips and falls, 2009*
- *Health and Safety Solution – Vacuuming, 2009*
- *Health and Safety Solution – Mopping, 2009*
- *Prevention of falls – ladders, 2006*

Other related publications

- *Children's Services Regulations, 2009 (available from legislation.vic.gov.au)*
- *Design guide for Victorian children's services, 2009 (available from education.vic.gov.au)*
- *Outdoor play guide for Victorian children's services, 2007 (available from education.vic.gov.au)*

Australian Standards

- *AS/NZS 4422:1996, Playground surfacing – specifications, requirements and test method*

Further information

WorkSafe Advisory Service

Toll-free 1800 136 089

Email: info@worksafe.vic.gov.au

worksafe.vic.gov.au

Further resources

WorkSafe Health and Safety Solutions

- *Lifting children in/out of cots and highchairs or on/off change tables*
- *Working at low levels in children's services*
- *Moving equipment in children's services*
- *Storing supplies and equipment in children's services*
- *Using office areas in children's services*
- *Maintaining indoor and outdoor areas in children's services*

WorkSafe publications

- *Manual Handling Code of Practice, 2000*
- *Guide to the Occupational Health and Safety Act 2004, 2005*
- *How WorkSafe applies the law in relation to Reasonably Practicable, 2007*
- *Getting help to improve health and safety, 2008*
- *Labour hire agencies: Managing the safety of on-hired workers, 2006*
- *Host employers: Managing the safety of labour hire workers, 2006*
- *Employee representation, 2006*
- *Information for health and safety representatives, 2006*
- *Information for employees on health and safety, 2006*
- *Childcare – Designing change table steps for children, 2009*
- *Injury hotspot: Children's services, 2008*

Other publications

- *Children's Services Regulations, 2009 (available from legislation.vic.gov.au)*
- *Design guide for Victorian children's services, 2009 (available from education.vic.gov.au)*
- *Outdoor play guide for Victorian children's services, 2007 (available from education.vic.gov.au)*

The information contained in this kit is copyright. The Victorian Workcover Authority hereby grants non-exclusive licence to the recipient of this kit on the condition that it is not disseminated for profit. The Victorian WorkCover Authority encourages the free transfer, copying and printing of the information in this kit, if such activities support the processes and intent for which the kit was developed, namely, to provide practical advice about the main hazardous tasks that cause workplace injuries in the children's services sector and how to control risks associated with these tasks.

WorkSafe acknowledges and thanks the children's services industry representatives who have contributed to the development of this kit.